

SPECTRUM SERIES

Section 1: Screen Design

1.1 What is it for?

Elite's **Spectrum Series** is a versatile electric motorized screen that fits perfectly in either residential or commercial wall/ceiling applications. Infrared and Ethernet control package included along with a 2-year manufacturer's warranty.

1.2 How does it work?

Its **MaxWhite®** 1.1 gain projection material displays a bright picture regardless of viewing angle.

Section 2: Product Features

2.1 Characteristics

Screen Material

- MaxWhite® material is durable and easy to clean
- 180° wide viewing angle with 1.1 gain
- Active 3D, 4K Ultra HD, and HDR Ready
- Not compatible with Ultra/Short-throw Projectors
- Standard black masking borders
- Also available in sound transparent material
- Available in the following diagonal sizes:
 - 84", 100", 120" and 180" in 4:3 format
 - 84", 100", 110", 125", 150" and 180" in 16:9 format
 - 85", 90", 106", 128" and 142" in 16:10 format

Design and Installation

- Durable casing for wall/ceiling installations
- Includes wood screws and drywall anchors
- Bubble leveler included
- Ships fully assembled with 3-prong power connection ready to plug & play
- Optional in-ceiling trim kit and 6" and 12" L brackets - sold separately

Control System

- Infrared (IR) remote control
- Detachable 3-way wall UP/STOP/DOWN switch

PRODUCT WHITE PAPER

<http://www.elitescreens.com>



- Built-in 5-12 volt trigger port enables Drop/Rise operation to synchronize with the projector's power cycle
- 12 Volt Trigger Cable included
- Low-voltage internal IR Receiver
- RJ45 input port allows easy integration with 3rd party control systems
- Optional RF Remote, wireless 5-12 volt trigger, Universal 5-12 volt trigger (for projectors that don't have a trigger output port) and In-wall switch - sold separately

Quality and Reliability

- Synchronous motor allows silent operation with extended operational longevity and low power consumption (84" - 128" models)
- Tubular motor allows swift operation and speed (142" models and above)
- Certified by AMX and CRESTRON
- AcousticPro UHD: Flame Retardant: Complies with NFPA 701 Standards
- Conforms to ANSI/UL STD. 60950-1
- Certified to CAN/CSA STD. C22.2
- GREENGUARD® and GREENGUARD® Gold Certified | UL 2818
- 2-year warranty from defects in workmanship
- 3-year warranty offered through ENR-G program (Education, Non-profit, Religious, and Government/Military)

2.2 Model Numbers

Model Number	Diag. Size	Aspect Ratio	Viewing Height (in)	Viewing Width (in)	Screen Material	Gain	Case Color	N.W. (lbs)	G.W. (lbs)	Packaging Dimensions (LxWxH)
Electric84V	84"	4:3	50.4	67.2	MaxWhite®	1.1	White	19.3	22.6	82"x5.5"x5"
Electric100V	100"	4:3	60.0	80.0	MaxWhite®	1.1	White	21.6	26.8	95.8"x5.5"x5.5"
Electric120V	120"	4:3	72.0	96.0	MaxWhite®	1.1	White	25.5	30.5	112"x5.5"x5.5"
Electric180V	180"	4:3	108.0	144.0	MaxWhite®	1.1	White	49.2	63.1	174.4"x6.5"x6.9"
Electric84H	84"	16:9	41.2	73.2	MaxWhite®	1.1	Black	18.4	22.6	87.8"x5.5"x5.5"
Electric100H	100"	16:9	49.0	87.2	MaxWhite®	1.1	Black	20.1	26.8	102.8"x5.5"x5.5"
Electric100H-A1080P2	100"	16:9	49.0	87.2	AcousticPro1080P2	1.1	Black	20.1	26.8	102.8"x5.5"x5.5"
Electric100H-AUHD	100"	16:9	49.0	87.2	AcousticPro UHD	1.1	Black	21.3	25.5	104.9"x5.3"x5.2"
Electric110H	110"	16:9	53.9	95.9	MaxWhite®	1.1	Black	23.6	30.0	111.8"x5.5"x5.9"

PRODUCT WHITE PAPER

<http://www.elitescreens.com>



Model Number	Diag. Size	Aspect Ratio	Viewing Height (in)	Viewing Width (in)	Screen Material	Gain	Case Color	N.W. (lbs)	G.W. (lbs)	Packaging Dimensions (LxWxH)
Electric125H	125"	16:9	61.3	109.0	MaxWhite®	1.1	Black	30.9	36.4	124.8"x5.5"x5.5"
Electric125H-A1080P2	125"	16:9	61.3	109.0	AcousticPro1080P2	1.0	Black	30.9	36.4	124.8"x5.5"x5.5"
Electric125H-AUHD	125"	16:9	61.3	109.0	AcousticPro UHD	1.1	Black	28.8	35.9	125.5"x5.7"x5.5"
Electric150H	150"	16:9	73.5	130.7	MaxWhite®	1.1	Black	35.3	41.9	146.5"x5.5"x5.9"
Electric180H	180"	16:9	88.3	156.9	MaxWhite®	1.1	Black	52.9	68.3	171"x6.7"x6.7"
Electric85X	85"	16:10	45.0	72.1	MaxWhite®	1.1	White	18.3	21.9	87.4"x5.5"x5.7"
Electric90X	90"	16:10	47.7	76.3	MaxWhite®	1.1	White	18.9	22.4	91"x5.5"x5.7"
Electric106X	106"	16:10	56.2	89.9	MaxWhite®	1.1	Black	21.0	25.9	106.1"x5.5"x5.5"
Electric128X	128"	16:10	67.8	108.5	MaxWhite®	1.1	Black	25.5	31.9	123.6"x5.5"x5.5"
Electric142X	142"	16:10	75.3	120.4	MaxWhite®	1.1	Black	39.9	47.4	135"x6.10"x6.3"

Section 3: Screen Material Specifications

3.1 Characteristics

3.1.1 MaxWhite®

MaxWhite® screen material is the most versatile screen surface for front projection presentations. This material provides the widest possible viewer angles with perfect diffusion uniformity while giving precise definition, image color reproduction and black & white contrast. Screen surface has black-backing to avoid light penetration and can be cleaned safely with mild soap and water. Woven screen material is a multi-layer, cross-array coated with a matte white reflective compound.

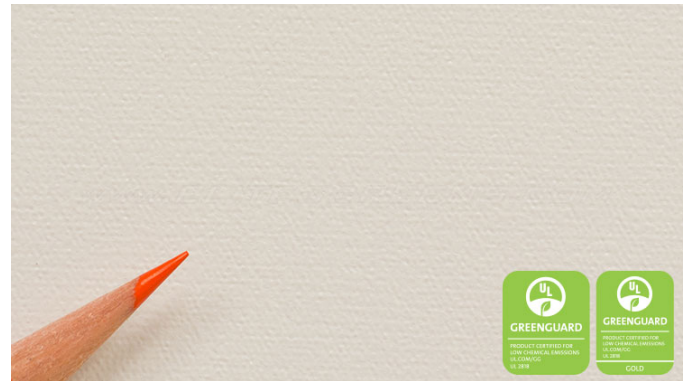

Features & Benefits

- Multi-layer weave and textured surface coating
- Gain: 1.1
- View Angle: 180° (90° ± LR)
- Not compatible with Ultra/Short-throw Projectors
- Mildew Resistant

Specifications	
Thickness	0.36 mm
Weight	350 g/m2
Maximum Height	3.2 M (10 ft)
On-axis Gain	1.0
Half-Gain Angle	Does not reach half gain

- Black backing
- Active 3D and 4K Ultra HD ready
- Surface can be easily cleaned with mild soap and water
- GREENGUARD® and GREENGUARD® Gold Certified | UL 2818

3.1.2 AcousticPro UHD

The **AcousticPro UHD (ultra-high definition)** is a moiré-free self-supported acoustically transparent front projection screen material. The dense synthetic weave is compatible with Ultra-High Definition/4K resolutions while mitigating light penetration for a brighter picture.

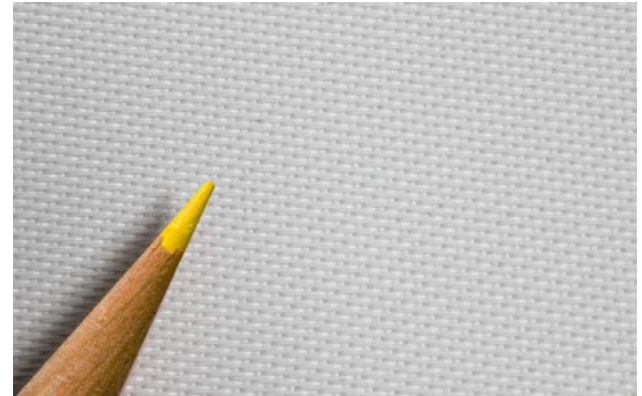

The **AcousticPro UHD** design maximizes sound penetration with minimal attenuation without compromising picture quality. The **AcousticPro UHD** material's wide diffusion uniformity offers a broad viewing angle with superb picture quality across the entire surface. This provides equal brightness levels on or off axis.

"Speaking of "observing", the Electric125H-AUHD performed admirably across a diversity of content and at all hours of day and night; its ambient light suppression was top-notch." – **Brian Dipert, EDN Network**

Features & Benefits

- Gain: 1.0
- Viewing Angle: 180° (90°L/R)
- Moiré-free
- Wide diffusion uniformity – maintains luminance levels throughout entire surface
- Mildew Resistant
- 4K UHD and Active 3D ready
- Mean Attenuation: -2.36dB
- Flame Retardant: Complies with NFPA 701 Standards

Specifications	
Thickness	0.64 mm
Weight	500 g/m2
Maximum Height	2.5 M (8.2 ft)
On-axis Gain	1.0
Half-Gain Angle	Does not reach half gain

3.1.3 AcousticPro 1080P2

The **AcousticPro1080P2** has a matte white surface with a 1.0 gain that provides excellent color neutrality for superb color reproduction along with wide diffusion uniformity. The angular weave material is designed to allow wall-speaker sound to breathe through the screen while eliminating the visual artifact known as moiré effect. The precision angled mesh of the material allows viewers to enjoy a visually

PRODUCT WHITE PAPER

<http://www.elitescreens.com>



superior presentation with strong color neutrality and artifact-free performance. The material is perfect for use with native 1080P projectors for home cinema and commercial applications.



Features & Benefits

- Acoustically Transparent Matte White (angular weave)
- Gain: 1.0 / Viewing Angle: 160° (80° L/R)
- Superb off-axis luminance
- Optimal color neutrality; color shift is not compromised
- Works best with 1080P DLP projectors and 720P (reduces moiré effect)
- Black backing eliminates backlighting artifacts from light bleed-through (only on fixed frame models)
- Mean attenuation of -2.05dB

Specifications	
Thickness	0.6 mm
Weight	500 g/m2
Maximum Height	2.5 M (8.2 ft)
On-axis Gain	1.0

3.2 Gain Chart

3.2.1 MaxWhite®



On axis 0° Gain: 1.1
Viewing Cone: 180°

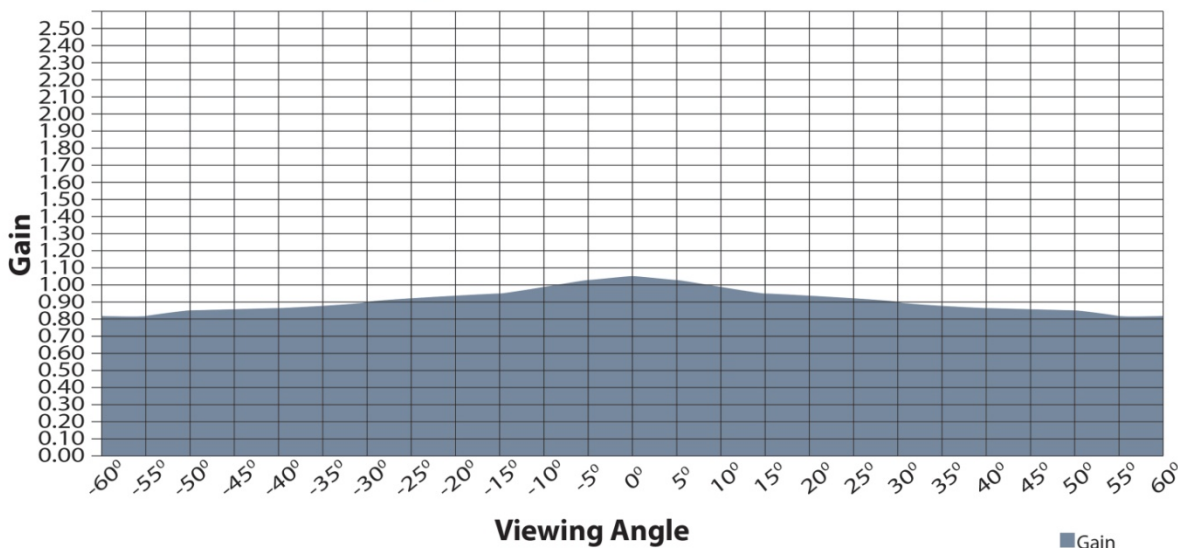

3.2.2 AcousticPro UHD



On axis 0° Gain: .80
Viewing Cone: 180°

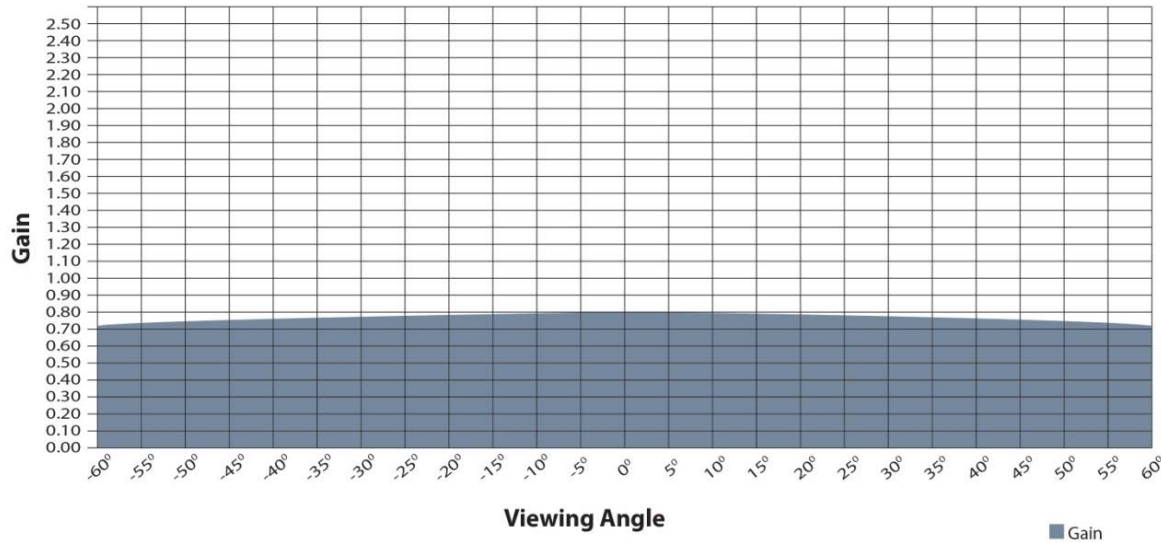

Section 4: Execution

4.1 Important Safety & Warning Precautions

Caution: The screen’s Black Top Drop is already set to its maximum drop distance. There is NO extra Black Top Drop in the roller. Please be aware of this, as it will void your warranty with Elite Screens. Unapproved changes or modifications (except for cutting the power cord for hardwire installations) to this unit are prohibited and will void your warranty. For more information, please contact our Technical Support Department at (877) 511-1211 Ext. 604.

- Please retain this user’s guide for future reference.
- To avoid damaging the unit, do not use with any unauthorized accessories not recommended by the manufacturer.
- Handle the unit carefully during transportation to avoid any damages.
- To ensure safe and reliable operation, direct connection to a properly grounded power source is advised.
- The power outlet supplying power to the unit should be close to the unit and easily accessible.
- Do not install the unit on uneven or inclined surfaces.
- Do not put heavy objects on the power cord and position it properly to avoid creating a trip obstacle.
- Never overload the power cord to prevent an electric shock or fire due to a loose contact or a short circuit.



- There are not user serviceable parts in this unit. Do not attempt to disassemble this unit by yourself. No one except authorized technicians can open and make repairs to this unit.
- Make sure the power source this unit is connected to has a continuous power flow.
- If there is need to use an extension cord, make sure the cord has an equal rating as the appliance to avoid overheating.
- Do not handle the power plug when your hands are wet or your feet are in contact with water.

Do not use this unit under the following circumstances.

- Disconnect the power cord under the conditions of heavy rain, wind, thunder or lightning.
- Avoid direct Sunshine, rain shower and moisture.
- Keep away from fire sources and high temperature to prevent this device from overheating.
- Cut off the power supply first before transportation or maintenance.
- Fully disconnect from the power supply when the unit is not in use for a long period of time, as should be done with any other electric household appliance.
- To avoid possible injury and/or an electric shock, do not attempt to use the screen if there is obvious damage or if there are any evident broken parts.

4.2 Installation Warning

Individual modifications to this product are prohibited and will void the warranty with the manufacturer. Please contact Elite Screens Customer Service for any questions.

NOTE: This equipment has been tested and found to comply with the limits for a Class B digital device, pursuant to Part 15 of the FCC Rules.

These limits are designed to provide reasonable protection against harmful interference in a residential installation. This equipment generates and can radiate radio frequency energy and, if not installed and used in accordance with the instructions, may cause harmful interference to radio communications.

However, there is no guarantee that the interference will not occur on a particular installation. If this equipment causes harmful interference to radio or television reception, which can be determined by turning the equipment off and on, the user is encouraged to try to correct the interference by one or more of the following measures.

- ✓ **Reorient or relocate the receiving antenna of the device which may be causing the interference.**
- ✓ **Increase the separation between the screen and the device's receiver.**
- ✓ **Connect the equipment into a different power outlet other than the device**

4.3 Pre-Installation

1. Carefully unpack the screen.
2. Always handle the screen in a leveled position on a clean surface.
3. In order to protect the screen from exposure to stains, keep the screen out of contact with foreign particles such as dust, sawdust, and/or liquids.

4.4 Accessories List

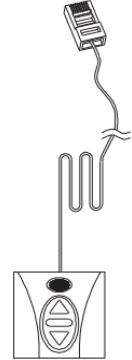
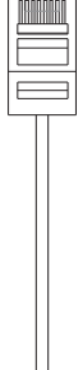
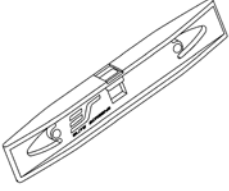
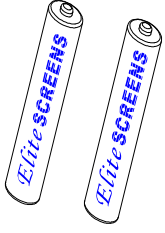
				
A. IR remote x 1	B. 3-way wall switch x 1	C. 12-volt trigger cable x 1	D. Bubble level x 1	E. AAA batteries x 2

4.5 Control System

1. 5-12V Trigger: The built-in 5-12V trigger input allows your screen to synchronize its drop & rise with the projector’s power cycle. The screen deploys when the projector powers up and will retract when the projector powers down. The 5-12 volt adaptor connects to your projector’s trigger output via a separate cable that may or may not be provided by the manufacturer of the projector. The trigger feature will not work without an output cable from the projector, but it can be tested by connecting the Red (+) and Green (-) cable to a 9-volt battery.

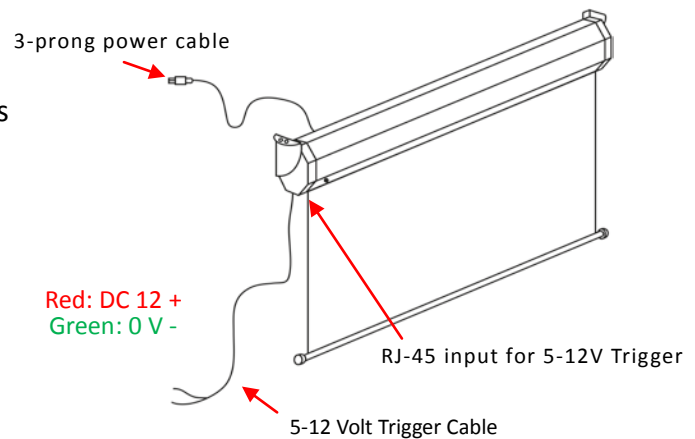

PRODUCT WHITE PAPER

<http://www.elitescreens.com>



2. 3-Way Wall Switch: The 3-way wall switch is a wall mount control box with an up/stop/down button and plugs directly into the screen's RJ-45 input.

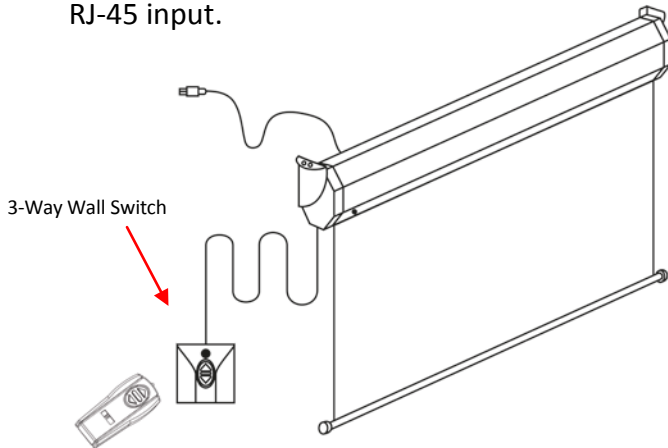

3. IR "Eye" Receiver: (sold separately) The IR "Eye" Receiver plugs directly into the screen's RJ-45 input to present a low profile line-of-sight control option for your IR remote control even in a recessed ceiling installation.

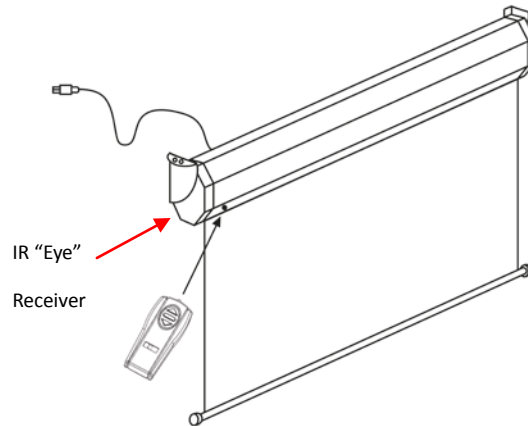

4. IR Remote Control: The Infrared functions by direct line of sight contact with a beam range of 30 feet.

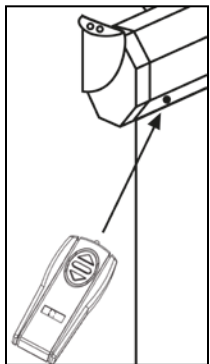

Note: The IR Remote MUST be within direct line of sight to the sensor to function. See figure to the left.

5. RF Remote Control: (sold separately) The radio waves eliminate the need for a direct line of sight with a range of 150 feet.

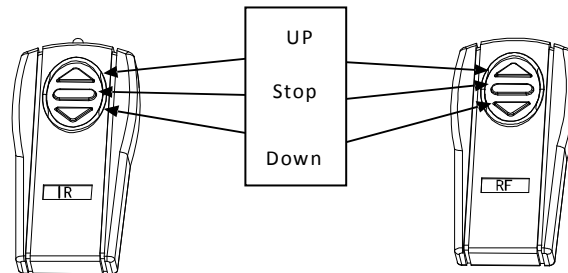

4.6 Installation Instructions

Please consult a professional installer. Elite Screens is not liable for any faulty installations.

1. Select the installation location for your screen. Ensure that it is within reasonable proximity from your power source.
2. For best support of your screen, it is ideal to secure your screen into the studs of your house's internal framework. If studs are not available, use hollow anchors for mounting your wall screws into drywall. If you're installing in a concrete structure, use concrete bolts to secure your screen.

Always consult a professional installer or hardware professional to ensure that the proper screws and/or hardware are being used.

3. Ensure that both brackets are in perfect level alignment with one another. Use wall/ceiling wood screws to secure to the wood studs. Use hollow anchors if mounting in drywall.

4. The screen casing is designed to accept the wall screws directly. If not using the Optional L-Brackets <http://shop.elitescreens.com/accessories.aspx>, be sure to position the washer between the head of the wall-screw and the anchor slots on the screen's casing.
5. Using a tape measure, mark the keyholes located at the back of the screen's casing end cap.
6. After marking the area and predrilled hole, insert the screw and have at least 1/8" from the wall to mount the screen. (See example in Figure 1.)
7. Figure 2 will show you an optional installation method using the drill holes located on top of the end caps for ceiling installation.

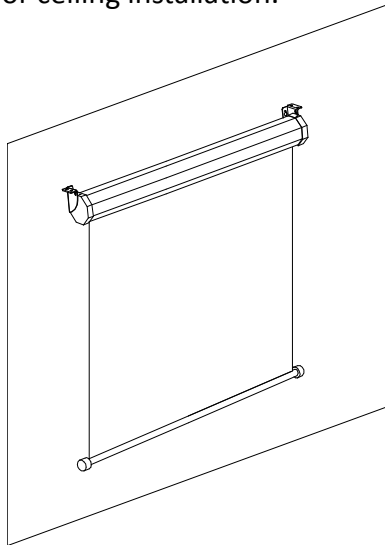
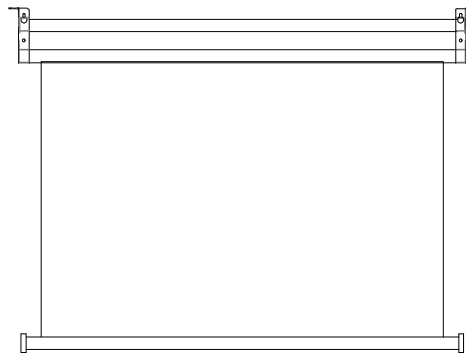
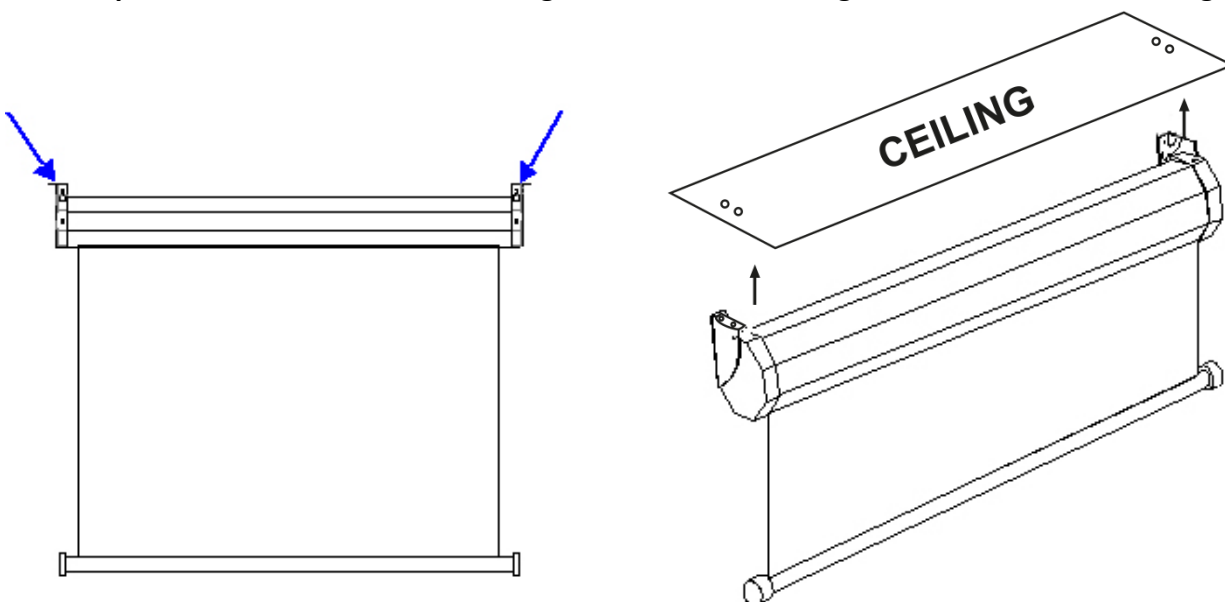

Fig. 1



Optional installation method using the drill holes to hang the screen from the ceiling



PRODUCT WHITE PAPER

<http://www.elitescreens.com>



Note:

Wall screws included with this product are complementary and may not be adequate for all mounting surfaces. Consult with a professional installer or hardware store for proper mounting screws and anchors.

Regardless of the mounting method, the screen should be securely supported so that the vibration or pulling on the viewing surface will not cause the screen case to become loose or fall. The installer must ensure that proper mounting hardware and the fasteners used are of adequate strength and suitable for the mounting surface.

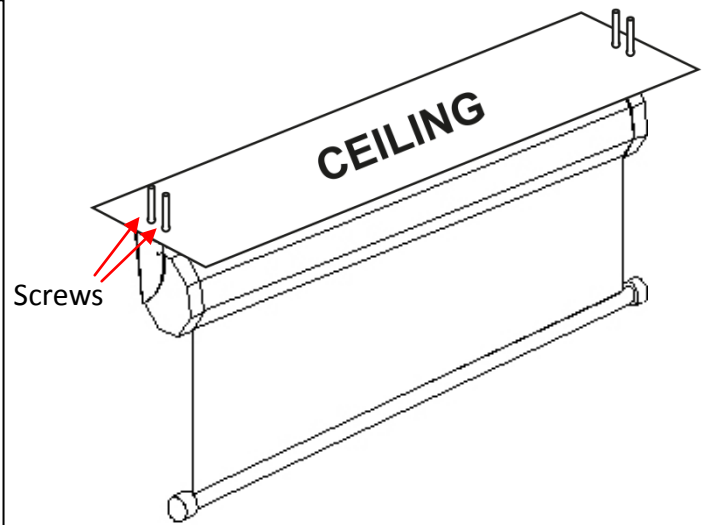

Section 5: Product Specifications

5.1 Dimensions

Model Number	A	A1	A2	A3	A4	B	B1	B2	B3	B4	B5	C1	C2	D
Unit: Inches														
Electric84V	79.4	67.2	70.2	77.2	73.3	64.4	50.4	60.7	2.4	3.7	8.0	0.7	3.1	70.9
Electric100V	93.1	80.0	83.9	91.0	87.1	71.0	60.0	67.4	2.4	3.7	5.0	0.7	3.1	70.9
Electric120V	109.2	96.0	99.9	107.0	103.1	82.0	72.0	78.3	2.4	3.7	4.0	0.7	3.1	70.9
Electric180V	155.4	144.0	148.0	153.2	151.1	118.5	108.0	114.4	2.4	4.1	4.0	0.7	3.5	70.9
Electric84H	85.4	73.2	76.2	83.2	79.4	55.2	41.2	51.5	2.4	3.7	8.0	0.7	3.1	70.9
Electric100H	100.2	87.2	91.1	98.0	94.3	61.1	49.0	57.4	2.4	3.7	6.0	0.7	3.1	70.9
Electric100H-A1080P2	100.2	87.2	91.1	98.0	94.3	61.1	49.0	57.4	2.4	3.7	6.0	0.7	3.1	70.9
Electric100H-AUHD	100.2	87.2	91.1	98.0	94.3	61.1	49.0	57.4	2.4	3.7	6.0	0.7	3.1	70.9
Electric110H	109.2	95.9	99.8	107.0	103.0	68.0	53.9	64.3	2.4	3.7	8.0	0.7	3.1	70.9
Electric125H	122.2	109.0	113.0	120.0	116.4	72.7	61.3	69.0	2.4	3.7	8.0	0.7	3.1	70.9
Electric125H-A1080P2	122.2	109.0	113.0	120.0	116.4	72.7	61.3	69.0	2.4	3.7	8.0	0.7	3.1	70.9
Electric125H-AUHD	122.2	109.0	113.0	120.0	116.4	72.7	61.3	69.0	2.4	3.7	8.0	0.7	3.1	70.9
Electric150H	142.6	130.7	134.7	140.4	137.8	84.1	73.5	79.9	2.4	4.1	4.0	0.7	3.5	98.4
Electric180H	168.3	156.9	160.8	166.2	164.0	100.7	88.3	96.6	2.4	4.1	6.0	0.7	3.5	98.4
Electric85X	84.3	72.1	75.1	82.1	78.2	55.1	45.0	51.4	2.4	3.7	4.0	0.7	3.1	70.9
Electric90X	88.5	76.3	79.3	86.3	82.5	57.7	47.7	54.1	2.4	3.7	4.0	0.7	3.1	70.9
Electric106X	103.1	89.9	93.8	100.9	97.0	66.2	56.2	62.6	2.4	3.7	4.0	0.7	3.1	70.9
Electric128X	121.7	108.5	111.5	119.5	115.6	77.9	67.8	74.2	2.4	3.7	4.0	0.7	3.1	70.9
Electric142X	132.3	120.4	124.4	130.1	127.5	105.7	75.3	101.6	2.4	4.1	4.0	0.7	3.1	98.4

PRODUCT WHITE PAPER

<http://www.elitescreens.com>



Model Number	A	A1	A2	A3	A4	B	B1	B2	B3	B4	B5	C1	C2	D
Unit: mm														
Electric84V	2016	1707	1783	1961	1863	1636	1280	1543	60	93	203	17	80	1800
Electric100V	2366	2032	2132	2311	2212	1804	1524	1711	60	93	127	17	80	1800
Electric120V	2773	2438	2538	2718	2618	2083	1829	1990	60	93	102	17	80	1800
Electric180V	3947	3658	3758	3892	3838	3010	2743	2905	60	105	102	17	88	1800
Electric84H	2168	1860	1936	2113	2016	1402	1046	1309	60	93	203	17	80	1800
Electric100H	2544	2214	2314	2489	2394	1551	1245	1458	60	93	152	17	80	1800
Electric100H-A1080P2	2544	2214	2314	2489	2394	1551	1245	1458	60	93	152	17	80	1800
Electric100H-AUHD	2544	2214	2314	2489	2394	1551	1245	1458	60	93	152	17	80	1800
Electric110H	2773	2435	2535	2718	2615	1726	1370	1633	60	93	203	17	80	1800
Electric125H	3103	2769	2869	3048	2956	1846	1557	1753	60	93	203	17	80	1800
Electric125H-A1080P2	3103	2769	2869	3048	2956	1846	1557	1753	60	93	203	17	80	1800
Electric125H-AUHD	3103	2769	2869	3048	2956	1846	1557	1753	60	93	203	17	80	1800
Electric150H	3622	3321	3421	3567	3501	2135	1868	2030	60	105	102	17	88	2500
Electric180H	4276	3985	4085	4221	4165	2559	2242	2454	60	105	152	17	88	2500
Electric85X	2140	1831	1907	2085	1987	1399	1144	1306	60	93	102	17	80	1800
Electric90X	2248	1939	2015	2193	2095	1466	1212	1373	60	93	102	17	80	1800
Electric106X	2618	2283	2383	2563	2463	1682	1427	1589	60	93	102	17	80	1800
Electric128X	3091	2756	2832	3036	2937	1978	1723	1885	60	93	102	17	80	1800
Electric142X	3360	3059	3159	3305	3239	2686	1912	2581	60	105	102	17	80	2500

5.2 Drawings

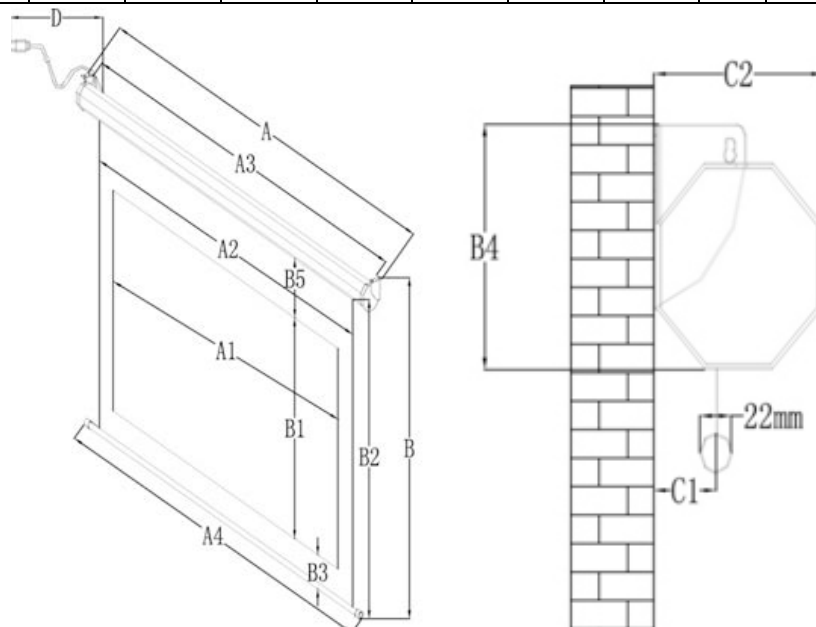

end cap for
84" - 128" sizes

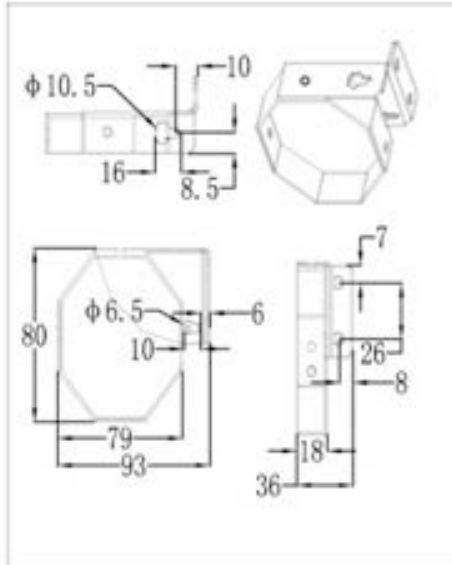

end cap for
135" - 180" sizes

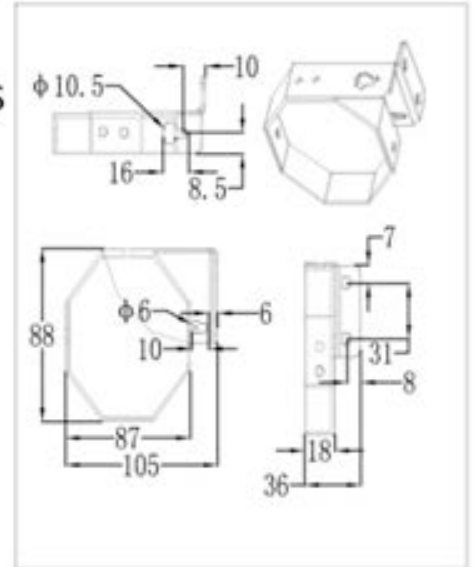

Unit of measure: mm

5.3 Pictures

Spectrum Series Available Aspect Ratios and Case Colors



PRODUCT WHITE PAPER

<http://www.elitescreens.com>



Spectrum Series with AcousticPro UHD Material



Weight Bar Detail



PRODUCT WHITE PAPER

<http://www.elitescreens.com>



IR Receiver and RJ-45 input Detail



Spectrum Series in Black and White housing



PRODUCT WHITE PAPER

<http://www.elitescreens.com>



Remote Kit



Suspended Ceiling Installation Example



PRODUCT WHITE PAPER

<http://www.elitescreens.com>



Life Style



Spectrum AcousticPro UHD Series
Sound Transparent Electric/Motorized Projection Screen

Elite Screens Inc. | Elite Screens Europe GmbH | Elite Screens France SAS | Elite Screens India
Elite Screens China Ltd. | Elite Screens Taiwan Corp. | Elite Screens Japan | Elite Screens Australia



Section 6: About Elite Screens

6.1 Company Description

Elite Screens Inc. is a California based company that specializes in making quality commercial and home-theater projection screens for the retail and custom install sales channels. Our company began as an innovative venture into the projection market by manufacturing veterans from the AV/IT industry. Elite Screens quickly established itself as an entry level commercial and home theater screen manufacturer. This was accomplished by making a quality product cost effective with a focus on mass-producing screen material, sizes and aspect ratios that were most commonly preferred by AV customers in general. We focused on uniformity with what would match the mainstream demographic while including extra features that are not usually included by other manufacturers. In time, we progressed from just retail sales into the realm of custom installer/integrator manufacture as our numerous reviews and awards will attest. We stand behind our product and are so certain of customer satisfaction with the quality of our product that we offer a 2-year manufacturer's warranty which is twice the industry standard. In our continued devotion to excellence in products and service, we are committed to implementing green practices with our production. We have adopted manufacturing methods that promote conservative regulation of our energy needs. Our simple product designs combined with the expertise of our permanent staff ensures that our entire line of products are made by experienced hands devoted to the high standards of today's audio-video consumer.

###